



Aria Podio 3

Headphones with
Charging Stand



Interactive User Guide

Version 1.9.2



First Time Setup

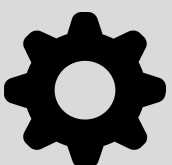

Troubleshooting

< Back



Main Menu

1. Before You Start
2. Buttons & Indicators
3. How to Charge
4. Device Setup
 - A. Use with Phone
 - B. Use with PC
5. Advanced Setup
6. Troubleshooting & FAQs
7. Get Help & Updates

Next

1. Before You Start

- Great for clear conversations: Equipped with **active noise cancellation** and a detachable noise-canceling **boom mic**.
- **Multipoint** connectivity: Connect to **two** devices at the same time and switch between them effortlessly.
- Extended playtime: Enjoy up to **55 hours** of use on a single charge.

[Next](#)

Was this helpful?



2. Buttons & Indicators

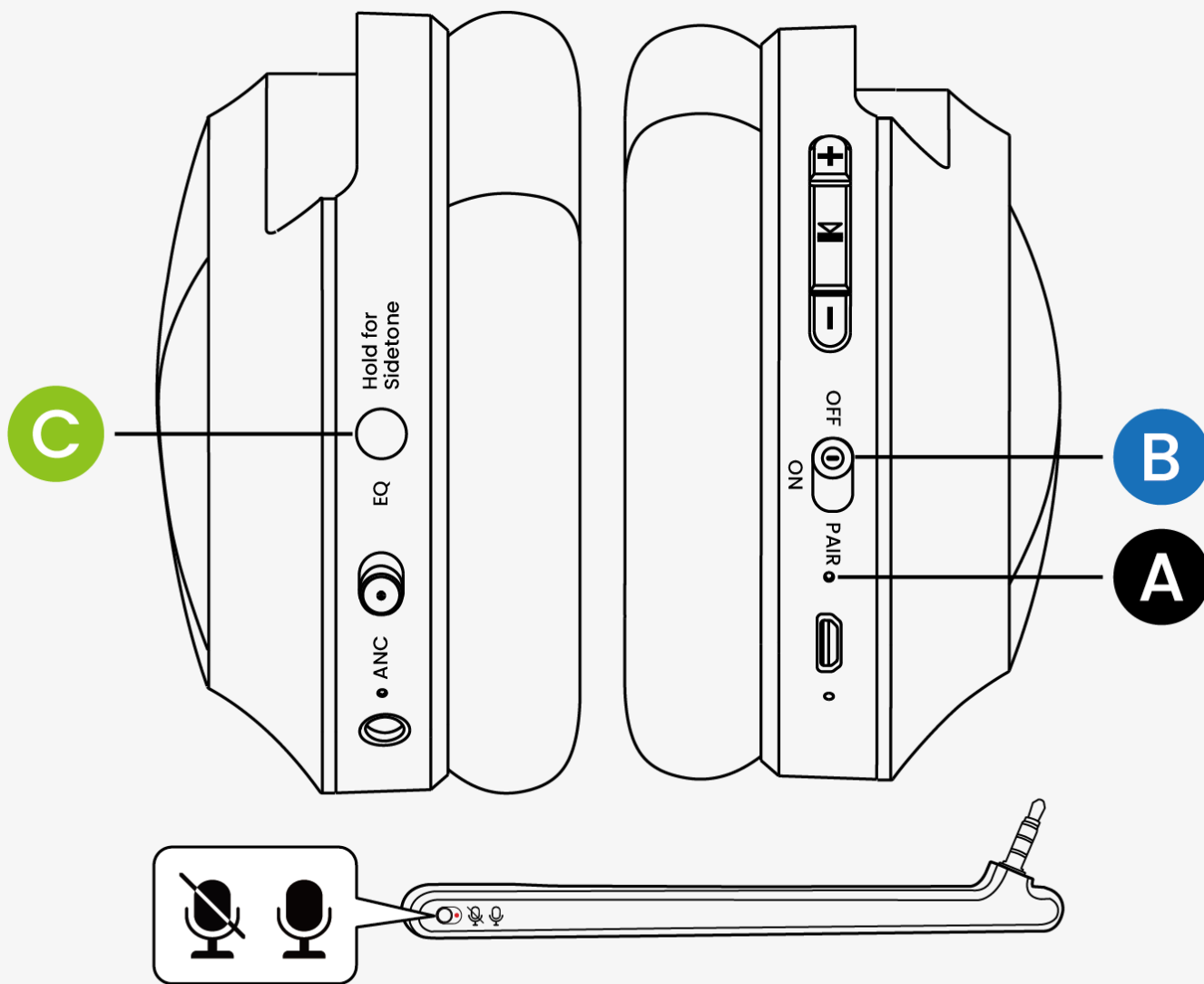

A LED Indicator

Solid → Connected

Blinking → Not Connected

B Switch

Hold to **PAIR** 3s → Pairing (**red** & **blue** flash)

C Sidetone

Hold **2s** → Toggle Sidetone (boom mic required)

[👉 Full Buttons & Indicators Guide ↗](#)

Next

Was this helpful?



3. How to Charge

- Use the stand or **USB-C** cable (5V, 1-2.4A).
- Charging: LED stays **solid red**.
- Fully charged: LED turns **off** (~2h).
- Playtime: Up to 55 hours.

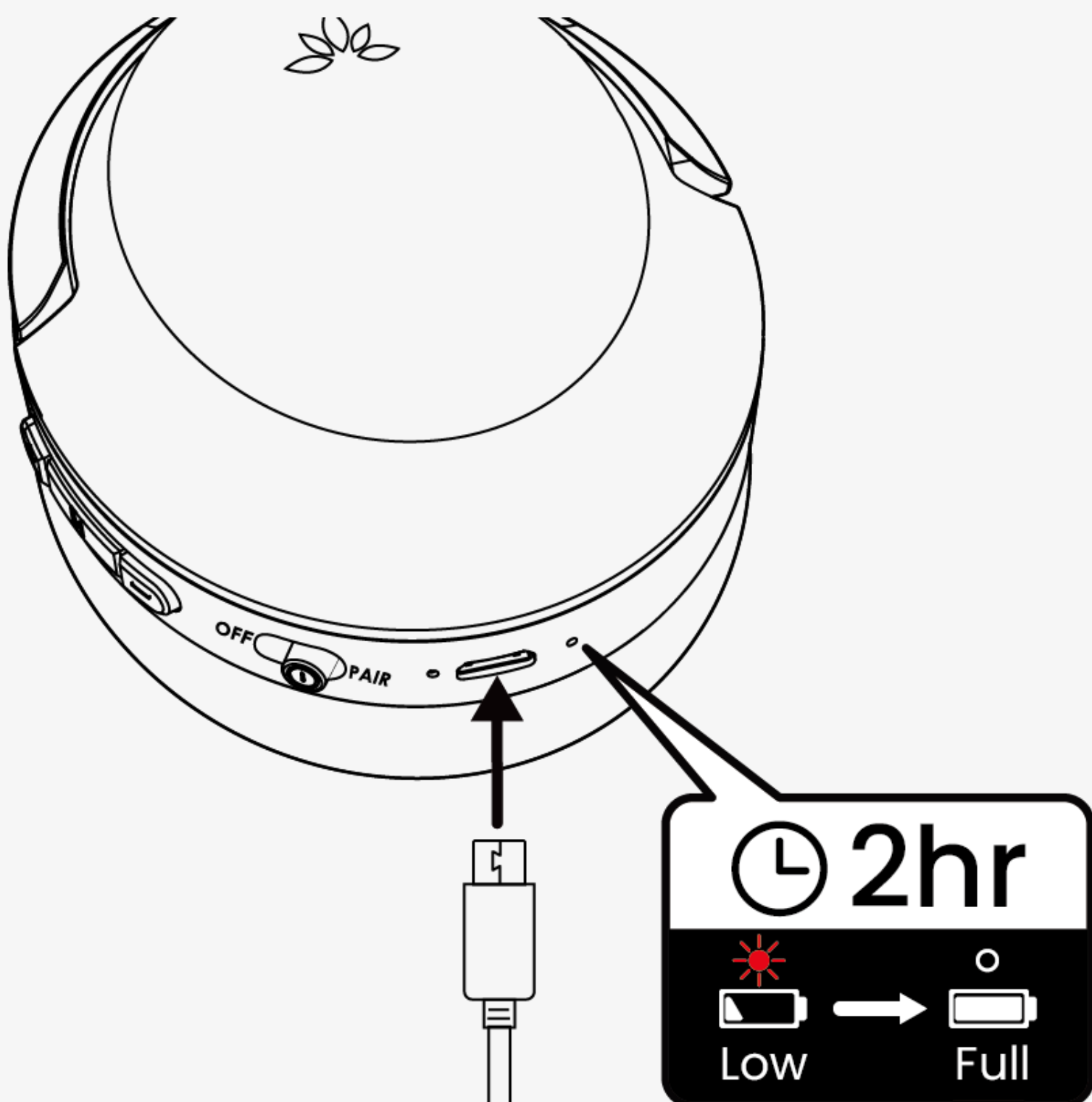

Next

Was this helpful?



< Back



Menu

4. Device Setup

Tap an option below to continue:

A

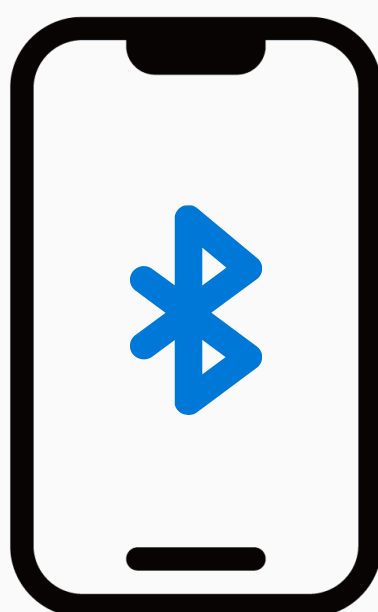

Phone

B

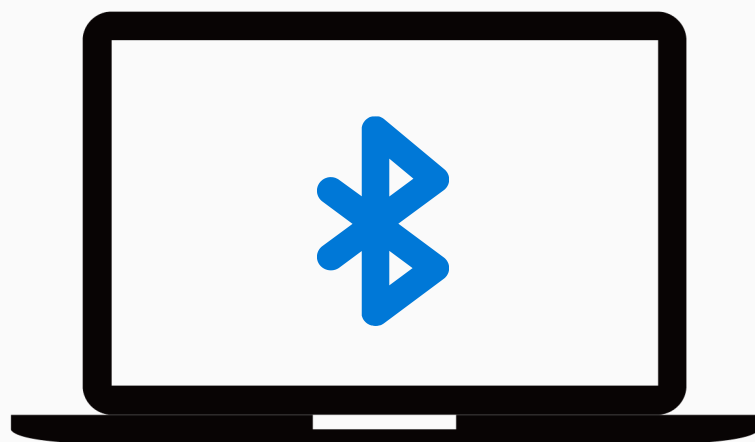

PC

Was this helpful?



A. Use with Phone

- 1 On phone: open **Bluetooth Settings**
- 2 Slide & hold to **PAIR**
LED flashes **red** & **blue**
On phone select "**Avantalk Aria Podio 3**"
- 3 Voice prompt "**connected**"
Play music normally



Next

Was this helpful?



B. Use with PC

① On PC: open **Bluetooth Settings**

② Slide & hold to **PAIR**

LED flashes **red** & **blue**

On PC select "**Avantalk Aria Podio 3**"

③ LED **solid** = connected

Play music, adjust volume



Next

Was this helpful?



< Back



Menu

B.2 Select your operating system

Set **Avantalk Aria Podio 3** as default input & output in audio settings.

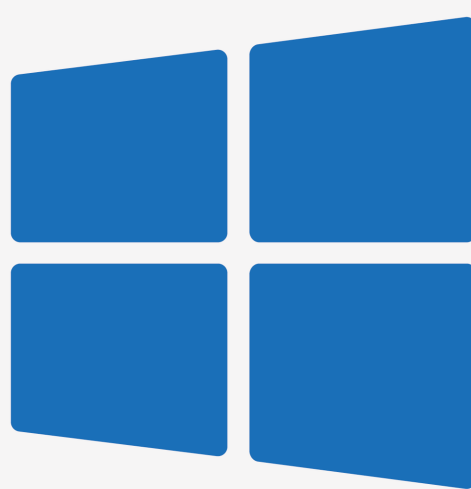

Windows



Mac

Was this helpful?



< Back

 Menu

B.2a Windows PC Sound Settings

1 Go to **Setting** → **Sound**

2 **Output**  → "Avantalk Aria Podio 3"

3 **Input**  → "Avantalk Aria Podio 3"

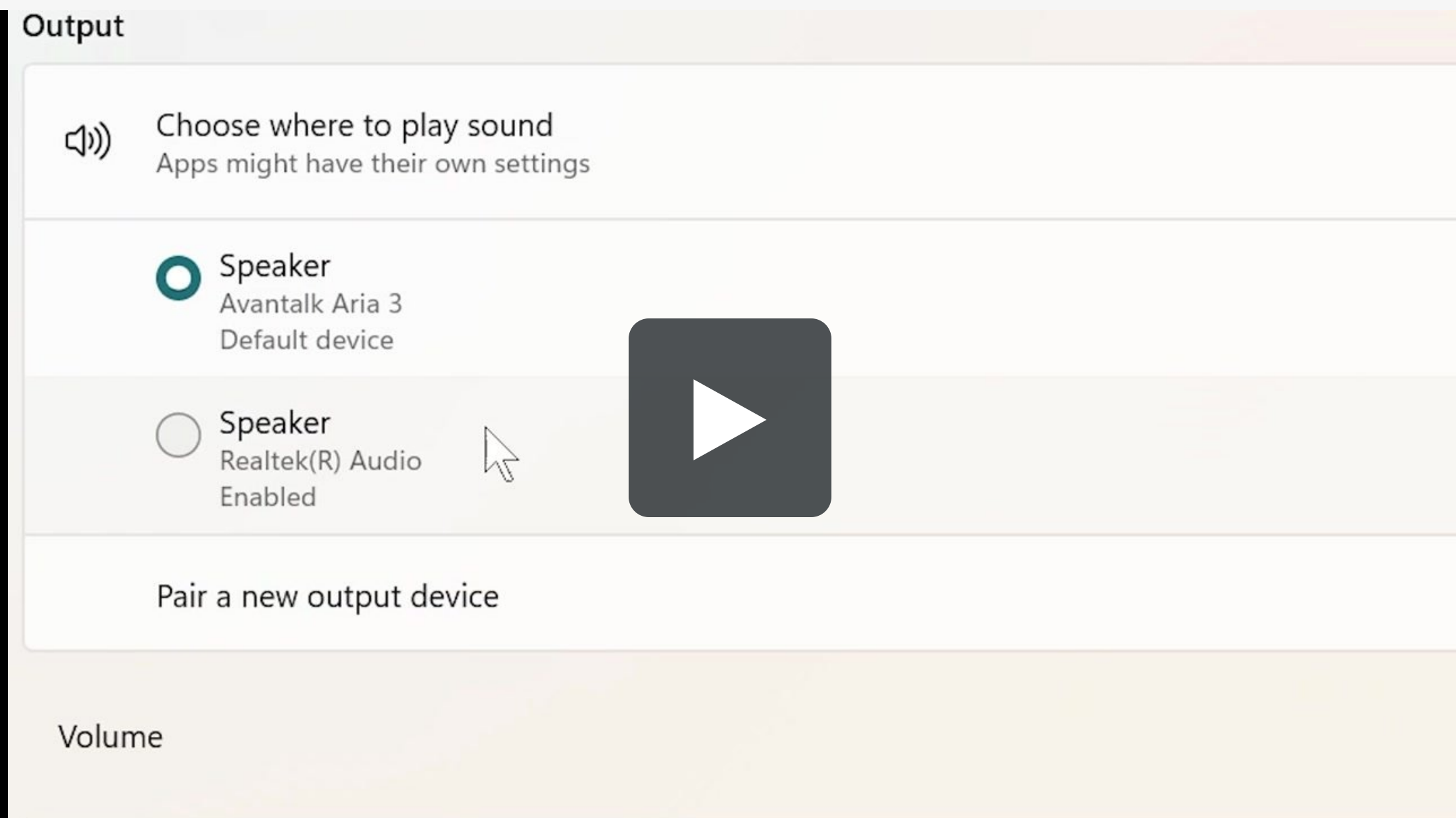

Next

Was this helpful?



< Back



B.2b Mac Sound Settings

① Go to **Setting** → **Sound**

② **Output**  → "Avantalk Aria Podio 3"

③ **Input**  → "Avantalk Aria Podio 3"

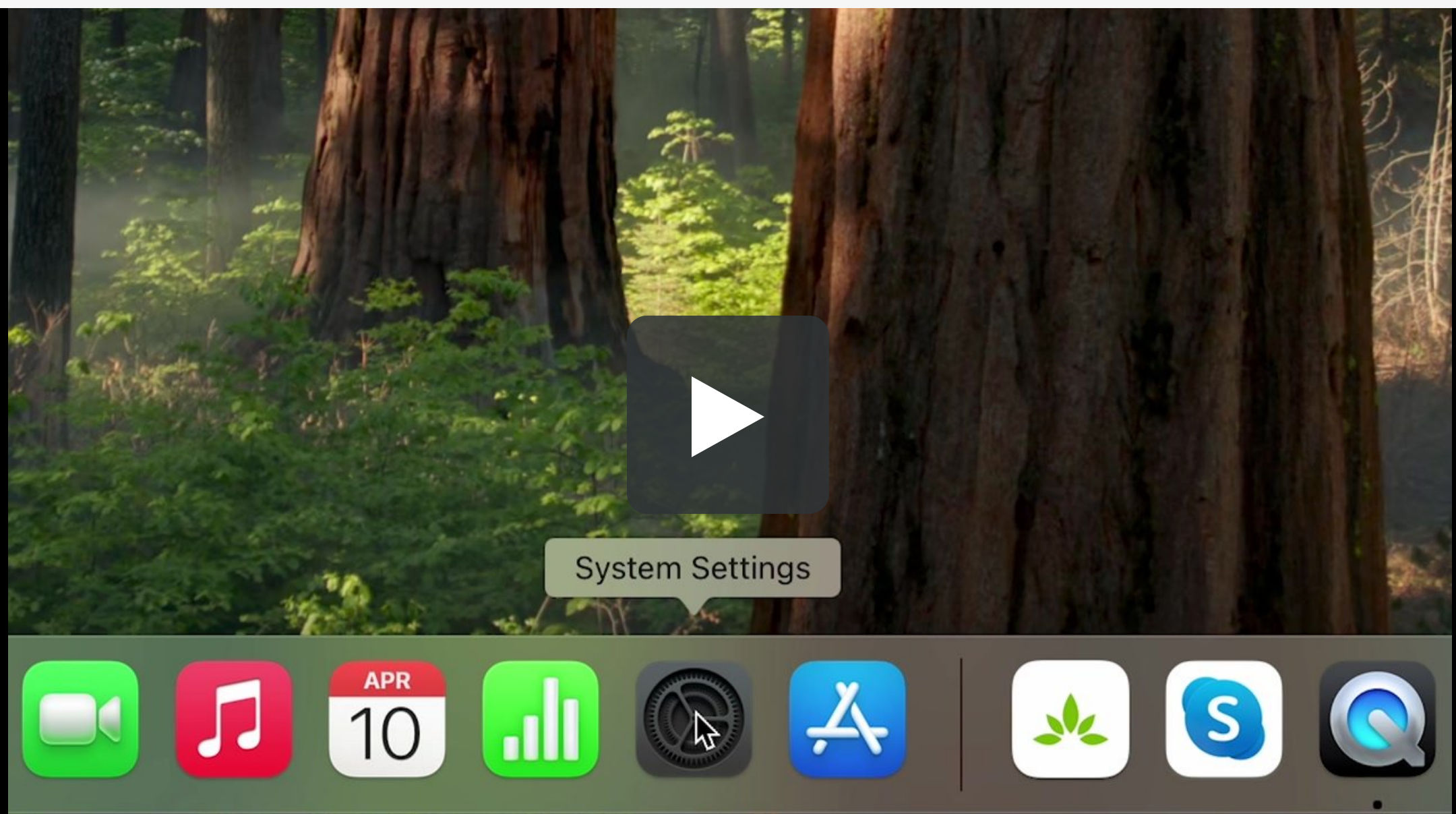

Next

Was this helpful?



B.3 App Sound Settings

If using an app to make calls, you may need to configure the app's settings as well.

a



[zoom](#)

b



[Teams](#)

c



[Discord](#)

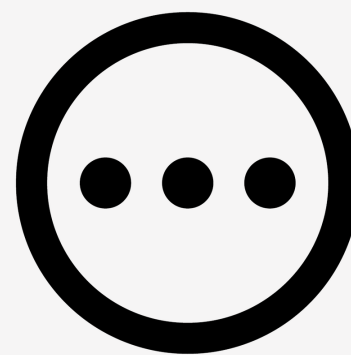

[Other](#)

Was this helpful?



B.3a Zoom Sound Settings

❶ Go to Zoom app → Settings → Audio

❷ Speaker  → "Aria Podio 3"

❸ Microphone  → "Aria Podio 3"

⚠️ If "Hands Free" and "Stereo" appear, select Hands Free.

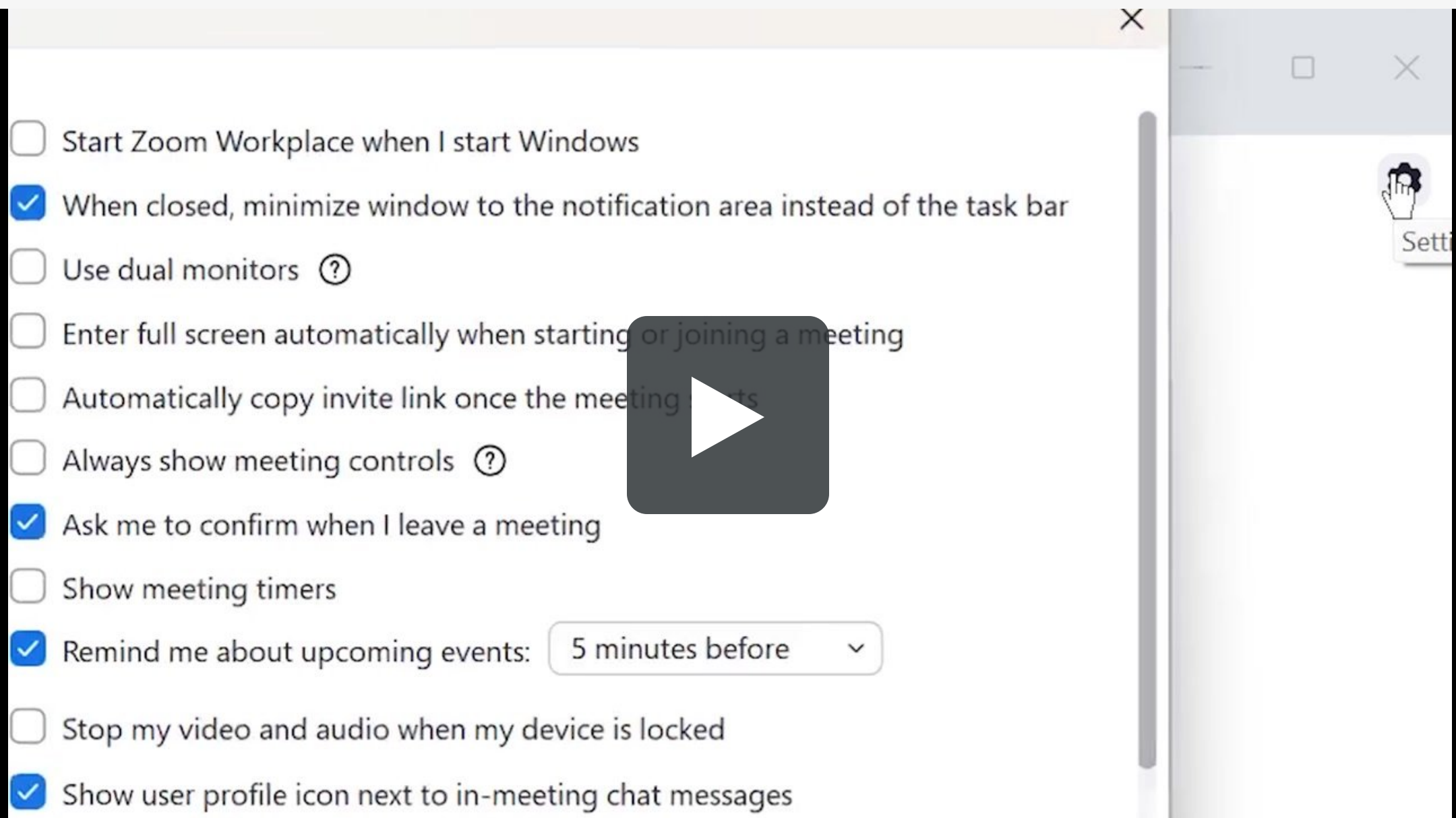

Next

Was this helpful?



< Back



B.3b Teams Sound Settings

1 Go to Teams app → Settings → Devices

2 Speaker  → "Aria Podio 3"

3 Microphone  → "Aria Podio 3"

⚠ If "Hands Free" and "Stereo" appear, select Hands Free.

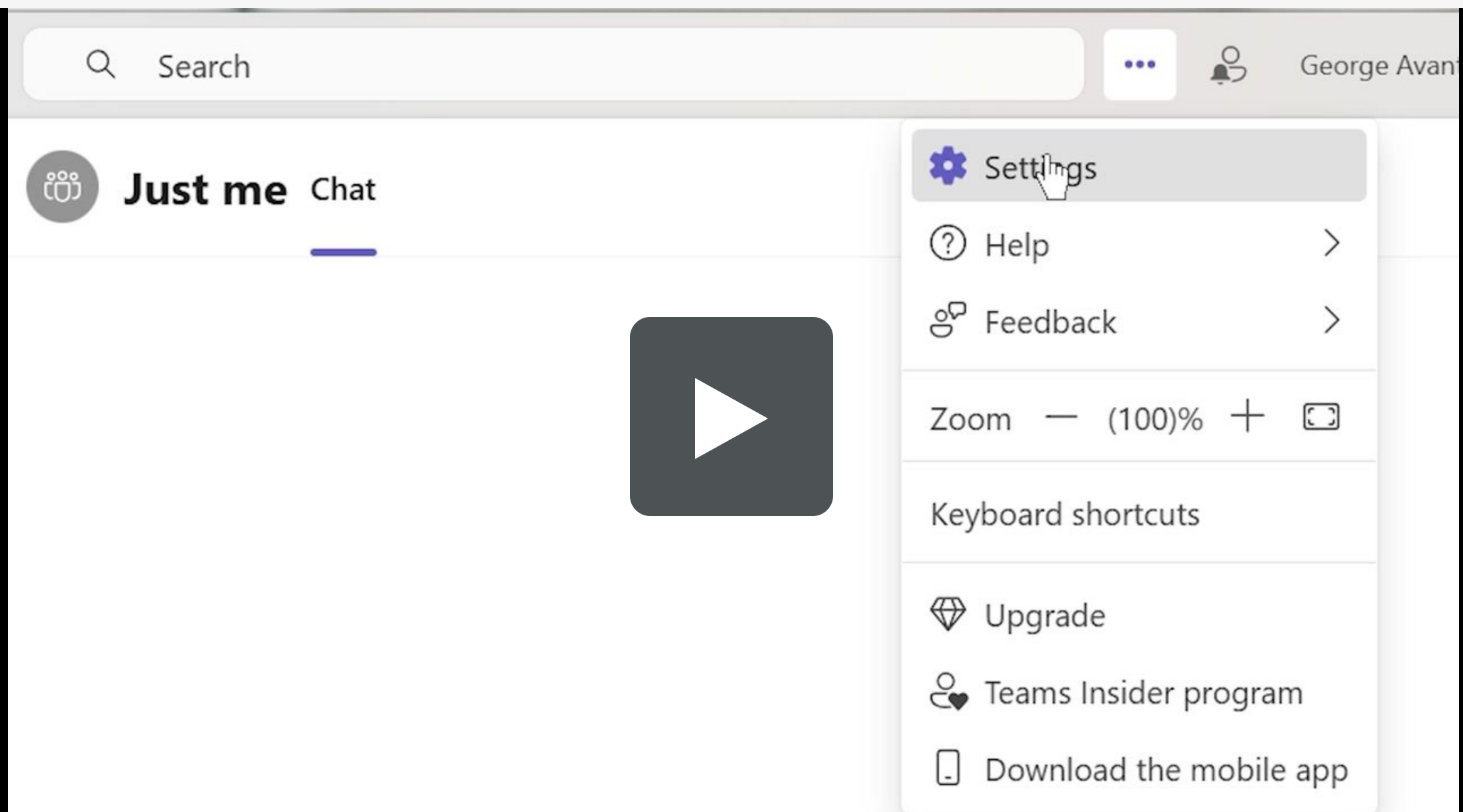

Next

Was this helpful?



< Back



Menu

B.3c Discord Sound Settings

① Go to Discord app → Settings → Voice & Video

② Output  → "Aria Podio 3"

③ Input  → "Aria Podio 3"

⚠ If "Hands Free" and "Stereo" appear, select Hands Free.

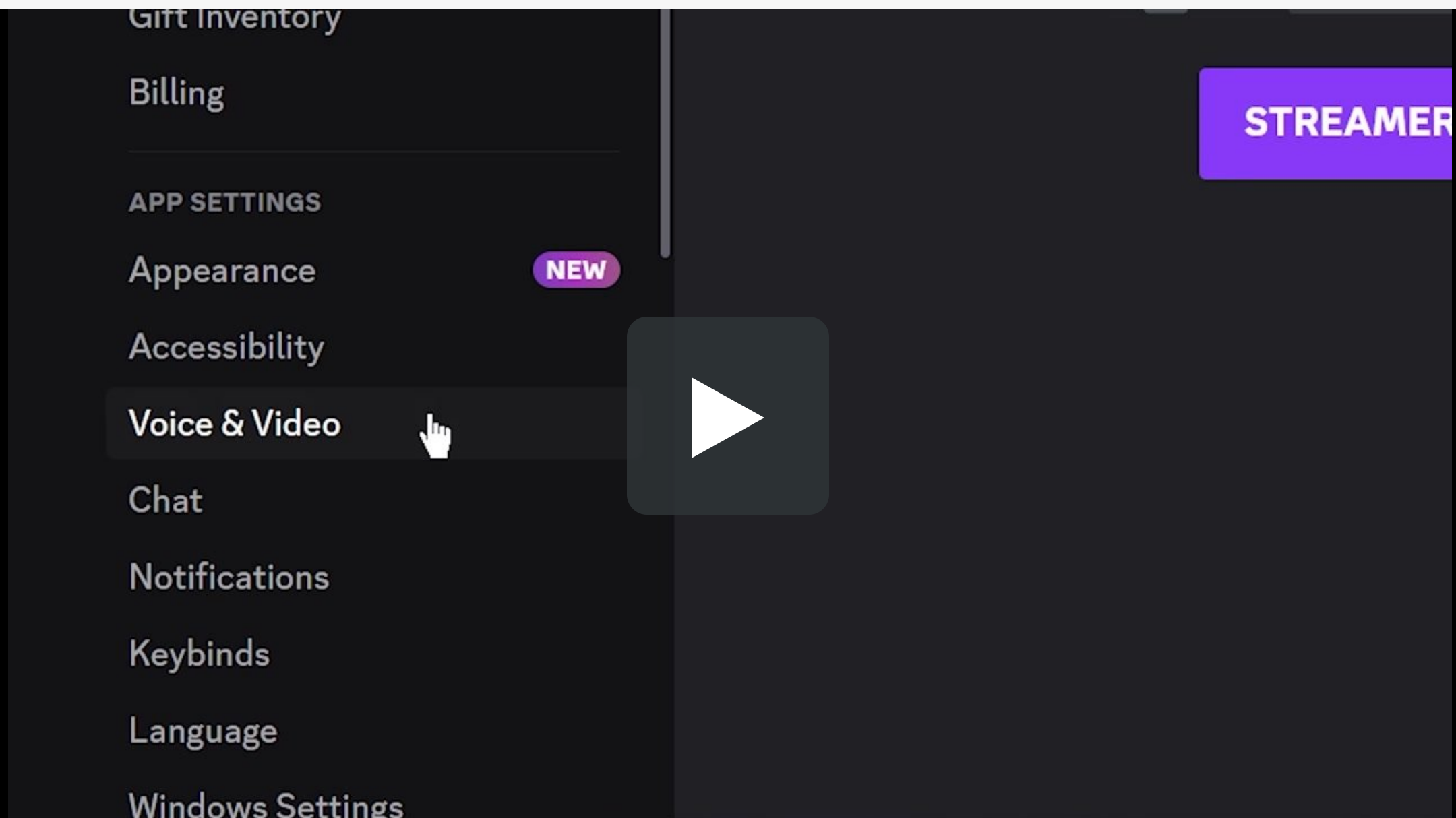

Next

Was this helpful?





5. Advanced Setup

A. Connect to Two Devices

The headphones support **multipoint pairing**. After connecting to the first device, put them in **Pairing** mode to connect to a second Bluetooth device. [[View more ↗](#)]

[Next](#)

Was this helpful?



< Back



Menu

B. Boom Mic

- 1 Plug the boom mic **firmly** into the port.
- 2 Ensure the mute switch is set to **OFF**.



Next

Was this helpful?





6. Troubleshooting

Common Issues

- [Dual link](#)
- [Reduce feedback](#)

 [More FAQ & Help](#) ↗

 *Still need help?* [Contact support](#) ↗

Next

Was this helpful?





7. Get Help & Updates

1. Register Your Product

Extended warranty & get updates.

[Register Your Product](#)

2. Agent Support

Need help? Contact our agents.

 Email

 Call

 Chat

3. Share Feedback

Your feedback is valuable.



[Rate This Guide](#)